



BituTHERM

THE INTELLIGENT WAY TO INSULATE

EXTRUDED POLYSTYRENE THERMAL INSULATION BOARDS

ألواح البوليستيرين باليثق للعزل الحراري



A product of
BITUMAT COMPANY LIMITED



WHAT IS THERMAL INSULATION

Thermal insulation is the method of preventing heat from entering the building (in Hot Climates) or escaping the building (in Cold Climates). The thermal insulators are referred to materials used to reduce the rate of heat transfer.

MODES OF HEAT TRANSFER

Heat flows naturally from a warmer to a cooler space. In winter, the heat moves directly from all heated living spaces to the outdoors and to adjacent unheated attics, garages, and basements wherever there is a difference in temperature. During the summer, heat moves from outdoors to the house interior. To maintain comfort, the heat lost in winter must be replaced by your heating system and the heat gained in summer must be removed by your air conditioner.

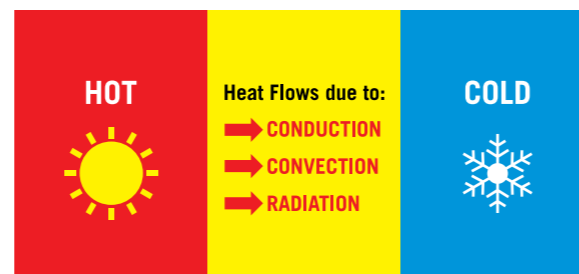

WHY INSULATE BUILDINGS?

Heating and cooling account for 50 to 70% of the energy used in an average home. Inadequate insulation and air leakage are leading causes of energy waste in most home.

- Reduce the consumption of electrical energy up to 40% during the cooling process Inside the building.
- Increases the level of comfort for the inhabitants In a building as It provides a cooler Interior ambience.
- The usage of AC Is minimized. This helps to reduce the cost of power consumption.

Technical



Hot Climate:In hot conditions, the greatest source of heat flow is solar radiation. The aim is to reduce the flow of heat inside the building.

Cold Climate:In cold conditions, the main aim is to reduce heat flow out of the building, to keep living space warm.

Environmental



“Go Green– Plan for a better tomorrow”. Use Energy as efficiently as possible.

Economical



The use of thermal insulation in building walls and roof does not only contribute in reducing the required air-conditioning/heating system size but also reducing the annual energy cost.

DIFFERENT PRODUCTS USED FOR THERMAL INSULATION

- Extruded Polystyrene Boards referred to as XPS
- Expanded Polystyrene Boards referred to as EPS
- Mineral wool
- Fiberglass
- Polyurethane Foam
- Polyisocyanurate

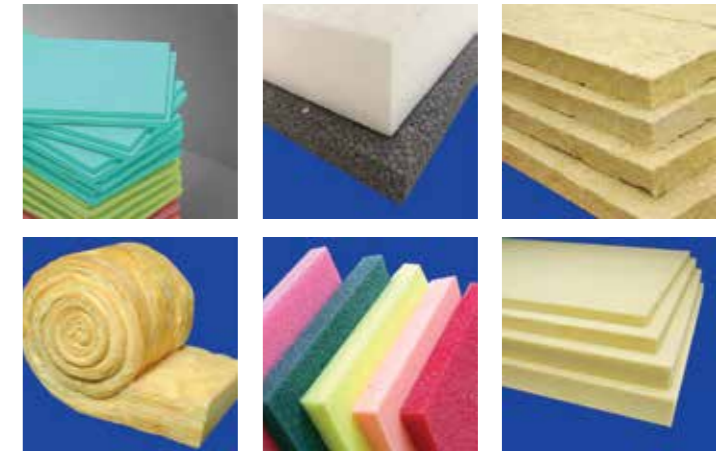

WHY EXTRUDED POLYSTYRENE FOR THERMAL INSULATION

The process of extruding foamed polystyrene results in a material with uniformly small, closed cells, a smooth ‘skin’ and an unrivalled set of properties which make it the choice of consultants in a wide range of demanding insulation applications.

The following properties makes Extruded Polystyrene an ideal choice for thermal insulation:

R- Value	Mechanical Properties	Moisture Resistance	Chemical Resistance
The ability of an insulation to resist heat flow. The higher the R-value, the greater the insulating power. XPS has excellent long term R-value and proven	High and uniform compressive strength.	The superior moisture resistance and very low vapour permeability of extruded polystyrene insulation provides outstanding benefits for most construction and engineering applications	XPS is resistant to many common chemicals such as: acids, bases, water and water-based paints, alcohol and alcohol-based paints, brine or salt water, cement and mortars, asphalt, etc

BITUMAT –BituTHERM

Bitumat BituTHERM is a thermal insulation Extruded Polystyrene material in form of rigid boards, made of polystyrene, (a derivative of petroleum) by using the extrusion method. The boards have a closed-cell structure and therefore they are resistant to water and humidity. They have excellent thermal insulation and compressive strength properties.

Specifications	
Dimensions	BituTHERM
Thickness	25,30,40,50,75,100 mm (Other thicknesses available upon request up to 180 mm)
Board Size	Standard size L 1250mm x W 600mm also available L 2500mm x W 1200mm
Edge Profiles	Shiplap
Colour	Green
Surface	Smooth

APPLICATION FIELDS

Bitumat BituTHERM is utilized for the thermal insulations of:

- Flat roofs, either accessible or non-utilizable, as inverted roof construction.
- Roof Gardens.
- Parking decks.
- Exterior walls of buildings insulated on outer surfaces
- Below-grade exterior walls of basements (Perimeter insulation).
- On-grade floors of buildings.
- Cold store Insulations.

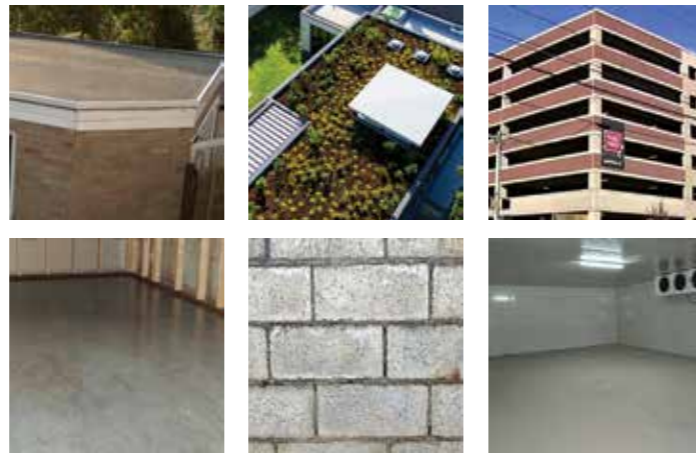

MULTIPLE-LAYER INSULATION

NRCA's recommended specification is for multiple-layer insulation. Bitumat urges double-layer application, especially when the total required thickness of XPS insulation is more than 2 inches (50 mm).

SOME OF THE COMMON INCORPORATED SYSTEM DESIGNS:

NON-UTILIZABLE FLAT ROOF INSULATION

No.	Roof Assembly Details
1	Reinforced concrete slab
2	Sloping screed
3	Bitumat Modified Waterproofing membrane
4	Bitumat "BituTHERM R" Insulation Board
5	Geotextile Separation Layer
6	Ballast
7	Parapet with Aluminum Skirting

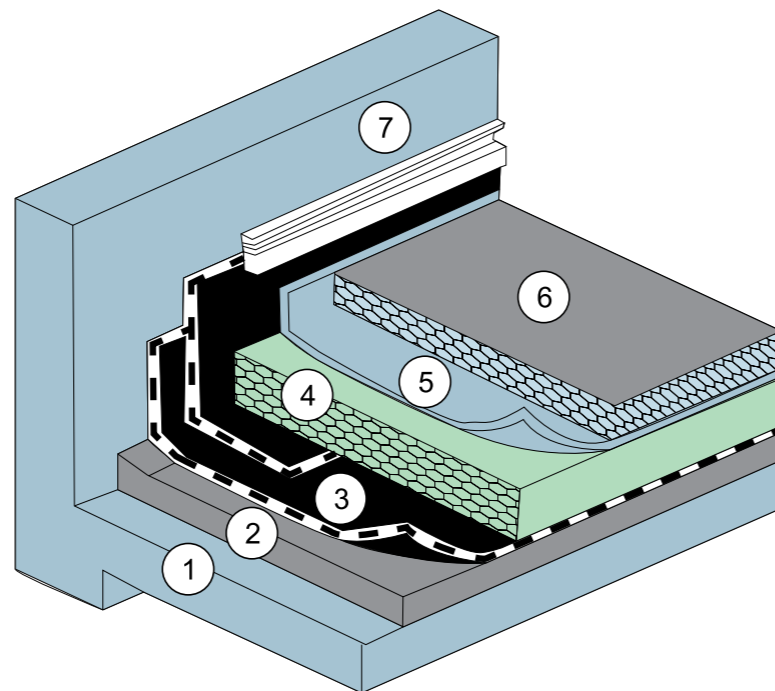

ACCESSIBLE FLAT ROOF INSULATION

No.	Roof Assembly Details
1	Reinforced concrete slab
2	Sloping screed
3	Bitumat Modified Waterproofing membrane
4	Bitumat "BituTHERM R" Insulation Board
5	Geo textile separation Layer
6	Paving slabs/ Tiles
7	Parapet with Aluminum Skirting

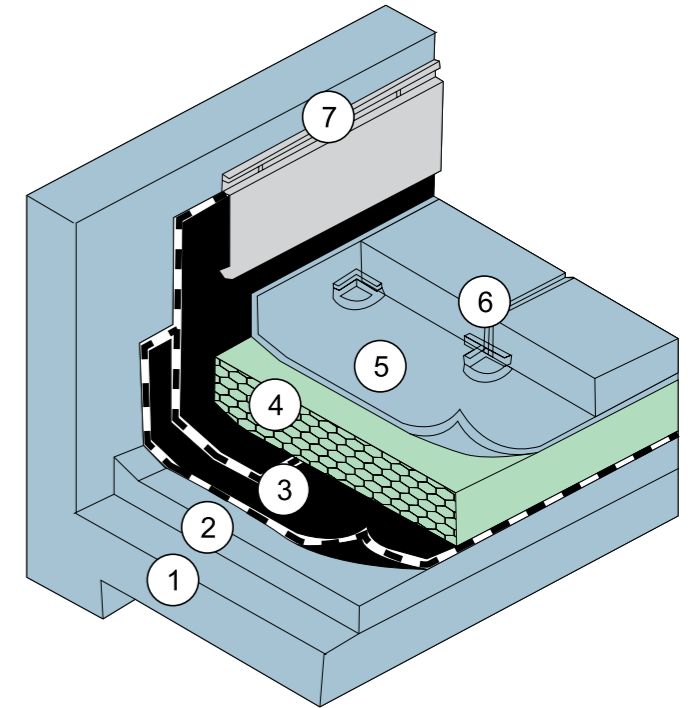

ROOF GARDEN INSULATION

No.	Roof Garden Details
1	Reinforced concrete slab
2	Sloping screed
3	Bitumat Modified Waterproofing membrane
4	Bitumat "BituTHERM R" Insulation Board
5	Geo textile separation Layer
6	Ballast
7	Geo textile separation Layer
8	Soil
9	Parapet with Aluminum Skirting

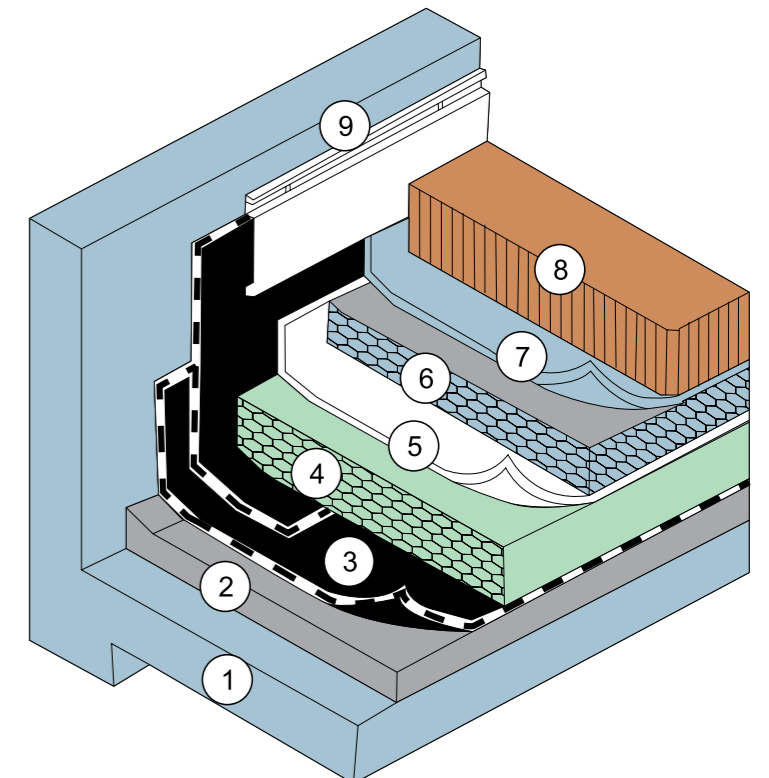

OUTSIDE INSULATION OF EXTERIOR WALL

No.	Wall Insulation Details
1	Exterior Wall
2	Fixing Mortar
3	Plastic Anchor
4	Bitumat "BituTHERM W" Insulation Board
5	Undercoat Plaster
6	Reinforcement Mesh
7	Undercoat Plaster
8	Plaster Finish

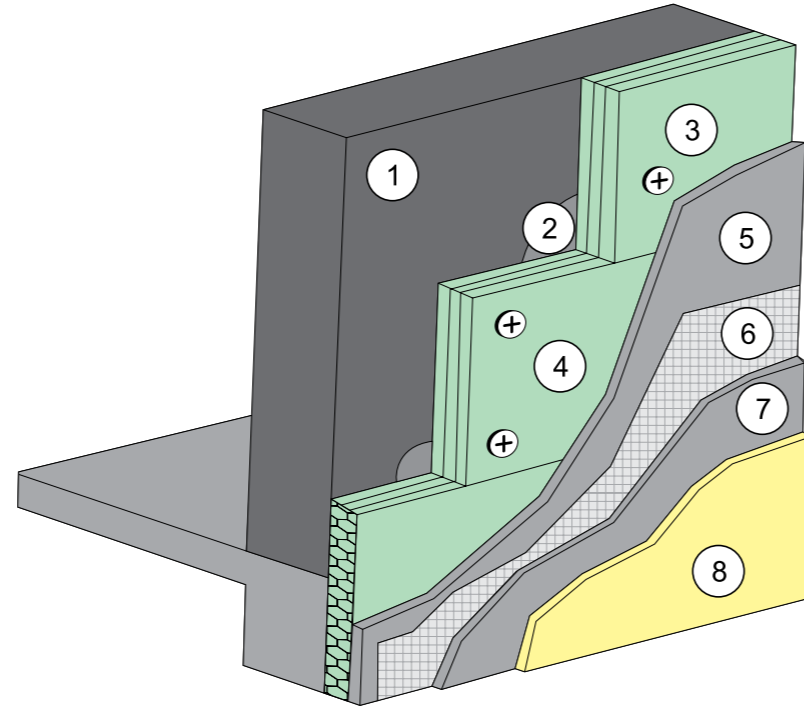

FLOOR INSULATION

No.	Floor Insulation Details
1	Stone fill hardcore
2	Leveling Concrete
3	Bitumat "BituTHERM F" XPS Insulation Board
4	Bitumat Modified Waterproofing membrane
5	Concrete Floor
6	Leveling Concrete
7	Floor Finish

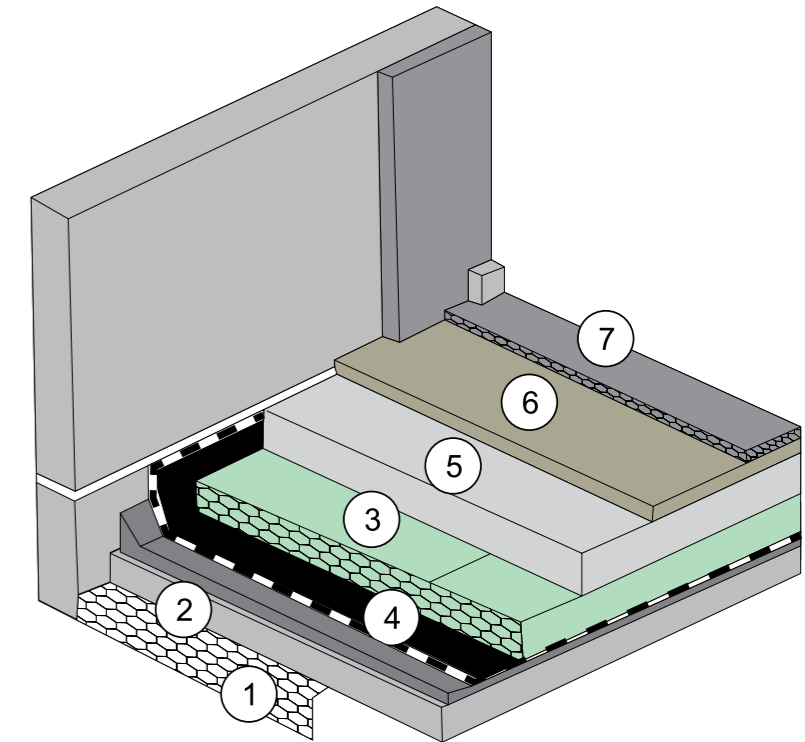

BELOW-GRADE EXTERIOR WALL INSULATION (PERIMETER INSULATION)

No.	Basement Insulation Details
1	Basement Wall
2	Leveling Plaster
3	Bitumat Modified Waterproofing membrane
4	Bitumat "BituTHERM W" Insulation Board
5	Protection Wall
6	Back Filling

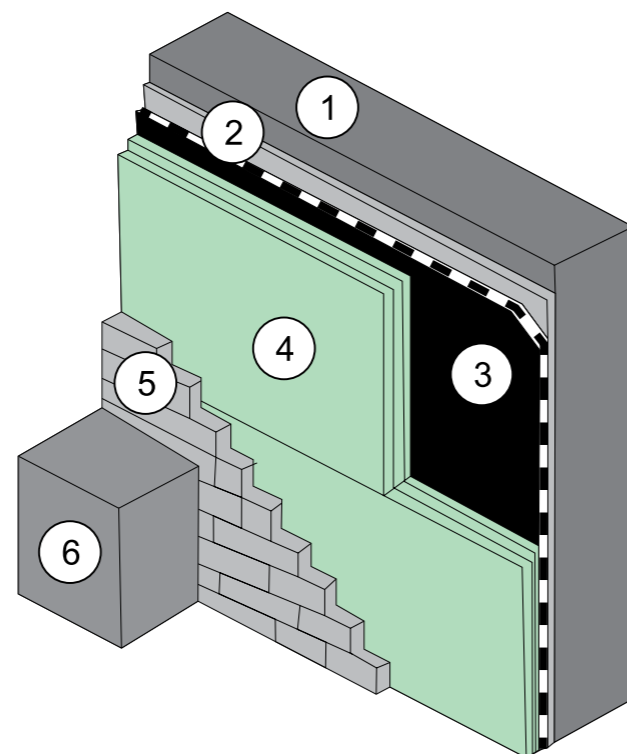

COLD STORE FLOOR INSULATION

No.	Floor Insulation Details
1	Reinforced Concrete Floor
2	Leveling Concrete
3	Bitumat Modified Waterproofing membrane
4	Bitumat "BituTHERM" XPS Insulation Board
5	Reinforced Concrete Slab
6	Mortar
7	Ceramic Tile

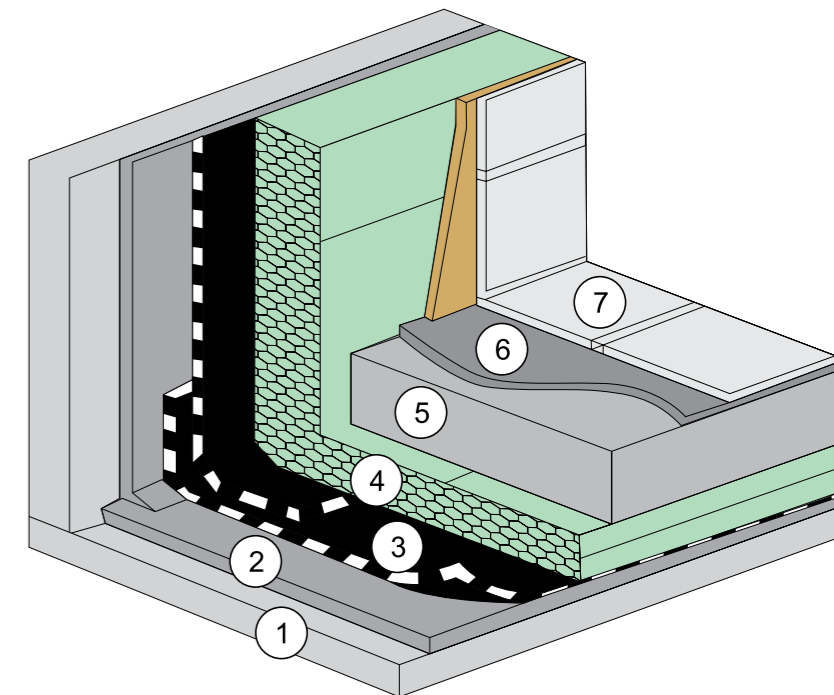



BituTHERM TECHNICAL DATA

“Typical Physical Properties - BituTHERM XPS BOARD”

S.No.	Properties	Test Method	Unit	LD	ND	MD	HD
1	Density, min.	ASTM D 1622	Kg/m ³ lb/ft ³	"26-28 1.6-1.7"	"32-35 2-2.2"	38-42 2.4-2.6	48-50 3.0-3.2
2	Thermal Conductivity (K)	ASTM C 518	w/mok Btu.in/sq.ft hr oF	"0.029 0.21"	"0.028 0.20"	"0.026 0.18"	"0.026 0.18"
3	Compressive Strength at 10% deflection, min	ASTM D 1621	"Psi kPa"	"26.0 180"	"45.0 300"	"70-100 480-700"	"100.0 700"
4	Flexural Strength, min	ASTM C203, Method I, Procedure B.	"Psi kPa"	"50 345"	"60 414"	"75 517"	"100 690"
5	Water Absorption by Submersion, min.	"ASTM D 2842 (+1% By vol. precision)"	% by vol.	0.30	0.30	0.30	0.30
6	Water Vapour Permeance, max	ASTM C 355	Perm/inch	1.50	1.10	1.10	1.10
7	"Dimensional Stability (Change in dimension), max."	ASTM D2126	%	2.0	2.0	2.0	2.0
8	Oxygen Index, min.	D2863	Vol., %	24.0	24.0	24.0	24.0
9	Fire Classification according to ASTM E84, standard method for Surface Burning Characteristics of Building Material under designation ASTM C578	ASTM E 84	-	Class I or A1	Class I or A1	Class I or A1	Class I or A1
10	Classification Type	ASTM C 578	-	IV	VI	VII	V

LD = Low Density - ND = Nominal Density - MD = Medium Density - HD = High Density

Bitumat BituTHERM is following the ASTM Standard C 578-

The information in this Technical Data Sheet is given to the best of our knowledge. However, as the product is often used under conditions beyond our control, we cannot guarantee but the product itself.

BITUMAT reserves the possibility to change, without warning, the technical characteristics in order to make the product more responding to the application requirements.



Global Business Solution
198-202, Nawabpur Tower, Room
No# 311, Nawabpur
Road, Nawabpur, Dhaka- 1100,
Bangladesh.

FOLLOW US ON

